

Scan 83 Series



Congratulations on your new Scan wood-burning stove

You have purchased a product by one of Europe's leading manufacturers of wood-burning stoves, and we are sure that you will have years of pleasure with your purchase. To make the best possible use of your stove, it is important that you follow our advice and instructions.

Read through this Assembly and Instruction Manual carefully before you start to assemble your stove.

Product registration number

Please indicate the product registration number at any enquiry

Table of contents

Technical data	3
Installation	
Safety	
Technical data and dimensions	
Dimensional drawings	
Type plate	
Product registration number	
Assembly	10
Loose parts	
Additional accessories	
Disposal of packaging	
Removal of packaging	
Height adjustment of stove	
Fresh air intake	
Closed combustion system	
Load-bearing subsurface	
Floor plate	
Existing chimney and pre-fabricated element chimney	
Connection between stove and steel chimney	
Requirements for chimney	
Connection with 90° elbow pipe	
Rotating base and 90° elbow pipe	
Positioning	
Distance to flammable materials	
Fitting the flue connection piece in the top outlet	
Fitting the flue connection piece in the rear outlet	
Fitting the natural stone sides	
Fitting the natural stone top	
Heat-storage stones Scan 83 Maxi models	
Mounting of the ceramic tiles	
Instructions for use	25
CB technology	
Primary air	
Secondary air	
Baffle plates	
Ash container	
Handle for riddling grate	
Adjustment of air supply	
The Clean Air Act	
Instructions for operation	27
Lighting	
Handling fuel	
Maintenance	29
Troubleshooting	33
Warranty	34

Installation

The house owner is responsible for ensuring that installation and assembly are in accordance with national and local building regulations as well as the information provided in this Assembly and Instruction Manual.

When you install any kind of fireplace or stove, you must inform the local building and housing authorities. In addition you are obliged to have the installation inspected and approved by a local chimney sweep prior to commissioning.

To ensure best possible functionality and safety for your installation, we advise you to call a professional fitter. Your Scan dealer will be able to recommend a qualified fitter in your area. For information on Scan dealers, please go to [http:// scan.dk](http://scan.dk).

Safety

Any changes made to the product by the dealer, fitter or user could result in the product and safety functions not functioning as intended. The same applies to the fitting of accessories or extra equipment not supplied by Scan A/S. This could also be the case if parts that are necessary for the operation and safety of the stove are dismantled or removed.



Scan 83-1
Handle and trims
in black aluminium



Scan 83-2
Handle and trims
in brushed aluminium



Scan 83-5
Natural stones/tiles, handle
and trims in black aluminium



Scan 83-6
Natural stones/tiles, handle
and trims in brushed aluminium



Scan 83-3
Maxi with handle and trims
in black aluminium



Scan 83-4
Maxi with handle and trims
in brushed aluminium



Scan 83-7
Maxi with natural stones,
handle and trims
in black aluminium



Scan 83-8
Maxi with natural stones,
handle and trims
in brushed aluminium

Technical data and dimensions

Materials	Steel plate, cast iron, galvanised sheet, vermiculite
Surface treatment	Senotherm
Max. log length (vertical position)	35 cm
Weight Scan 83-1 / 83-2	approx. 117 kg
Weight Scan 83-3 / 83-4	approx. 125 kg
Weight Scan 83-5/6, natural stone/tile	approx. 186/132 kg
Weight Scan 83-7 / 83-8	approx. 212 kg
Fresh air connection piece external diameter	100 mm
Flue connection piece internal diameter	144 mm
Flue connection piece external diameter	148 mm
Approval type	Intermittent operation

Intermittent operation in this context means normal use of a wood-burning stove. In other words, you should let the fire die down until only the embers are left before refuelling.

The Scan 83 Series is produced in accordance with type approval for the product, which also covers the product's Assembly and Instruction Manual.

The Declaration of Performance (DoP) is available from <http://scan.dk>

Tested in accordance with EN 13240

Scan 83 Series	Technical data	Unit
CO emissions at 13% O ₂	* 0.07	%
CO emissions at 13% O ₂	896	mg/Nm ³
Dust @ 13% O ₂	23	mg/Nm ³
No _x @ 13% O ₂	106	mg/Nm ³
Efficiency	81	%
Energy efficiency index	108,5	
Energy efficiency class	A+	
Nominal output	5	kW
Chimney temperature EN 13240	227	°C
Temperature in flue connection piece	280	°C
Amount of smoke	5	g/sec
Negative pressure EN 13240	12	Pa
Recommended negative pressure in flue connection piece	16	Pa
Required combustion air supply	14	Nm ³ /h
Fuel	Wood	Wood
Fuel consumption	1.6	kg/h
Amount of fuel required to light	1.4	kg

* based on 896 mg/Nm³

Dimensional drawing for Scan 83-1 and Scan 83-2

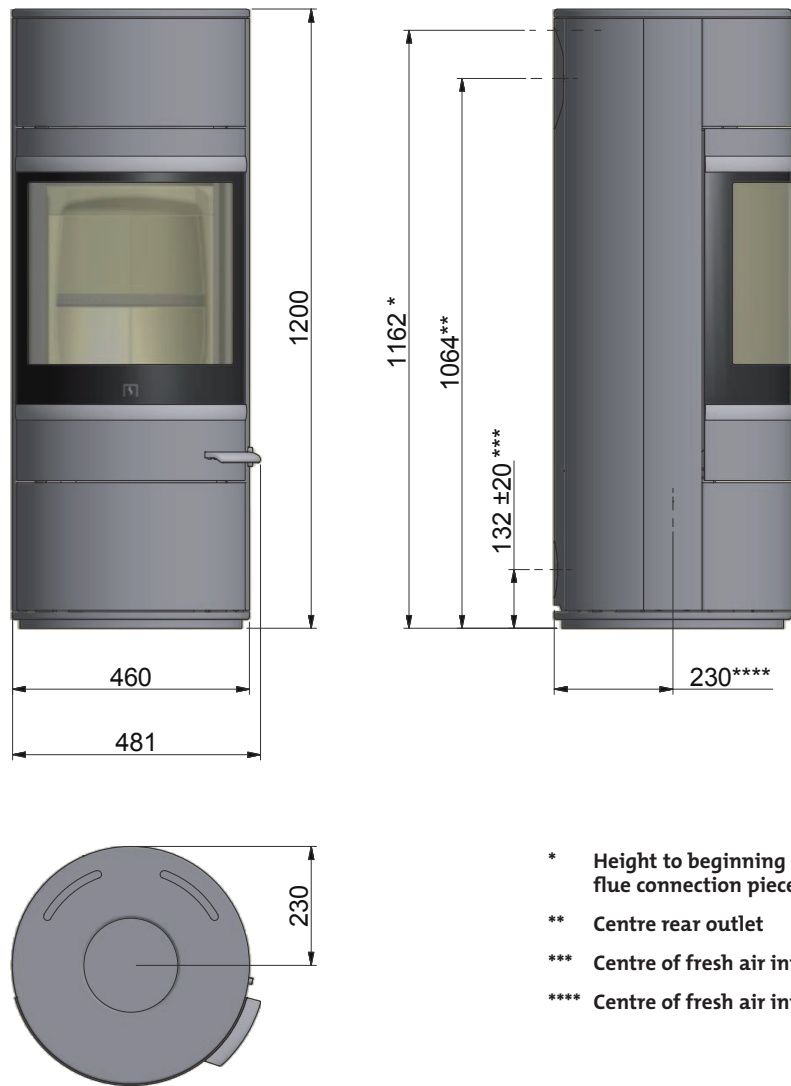

Dimensional drawing for Scan 83-3 and Scan 83-4

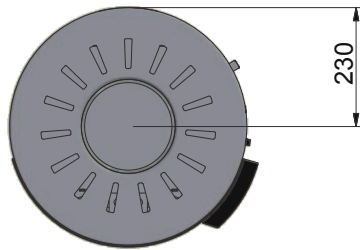
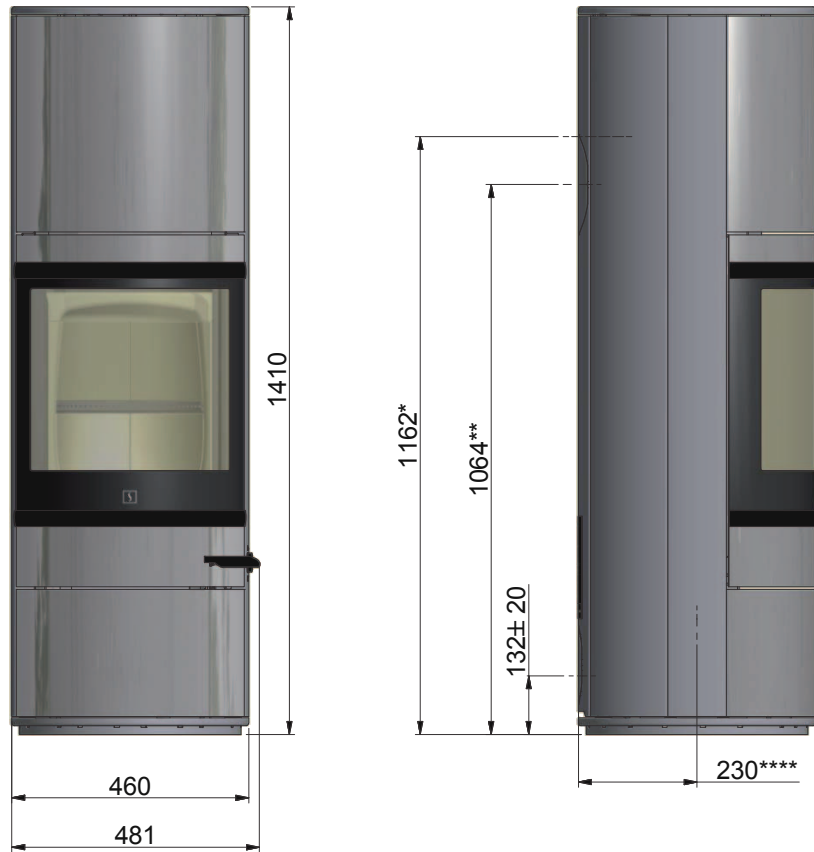

- * Height to beginning of flue connection piece at top outlet
- ** Centre rear outlet
- *** Centre of fresh air intake rear outlet
- **** Centre of fresh air intake bottom

Dimensional drawing for Scan 83-5 and Scan 83-6 with natural stones/tiles

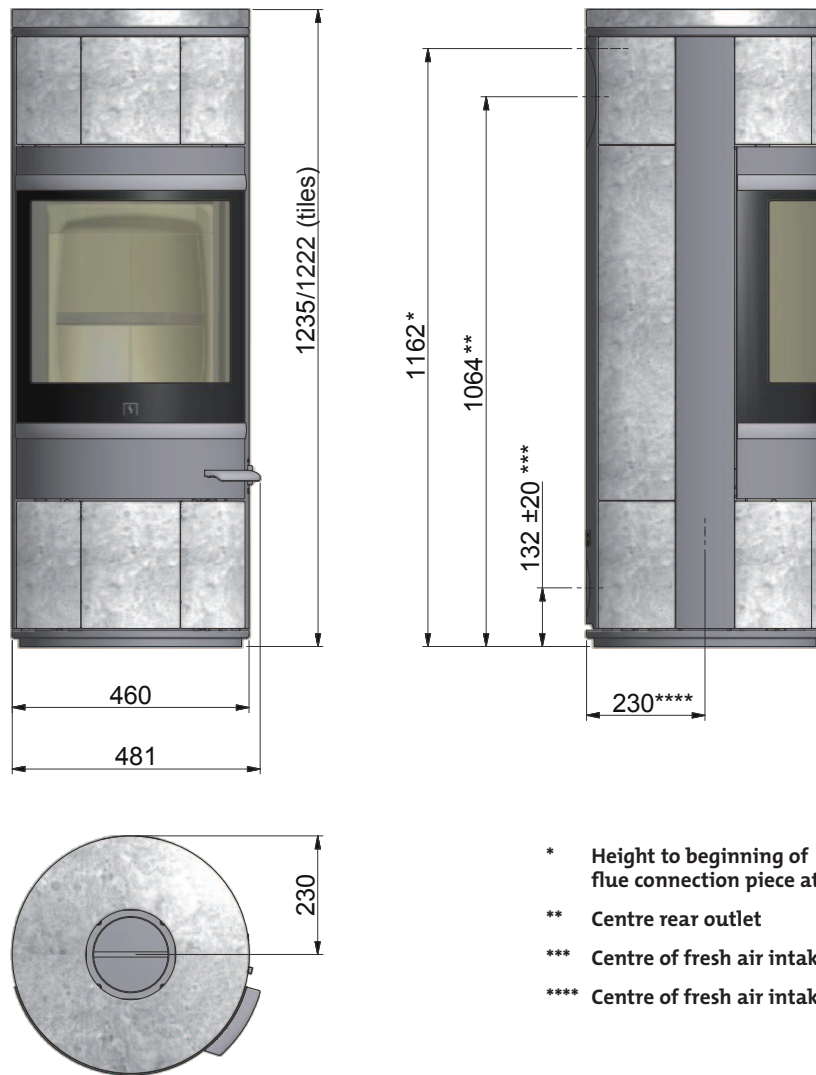

Dimensional drawing for Scan 83-7 and Scan 83-8 with natural stones

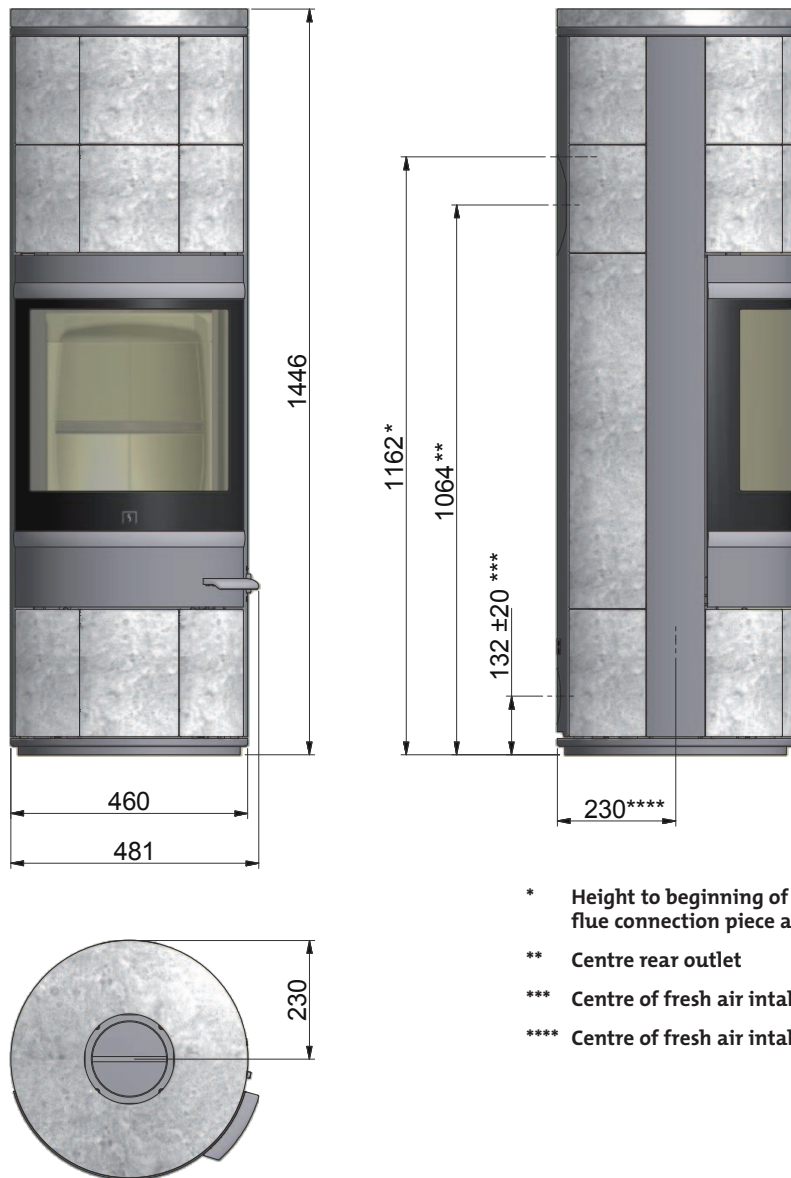

Type plate

All Scan wood-burning stoves are fitted with a type plate that specifies the approval standards and the distance to flammable materials.

The type plate is located at the rear of the stove.

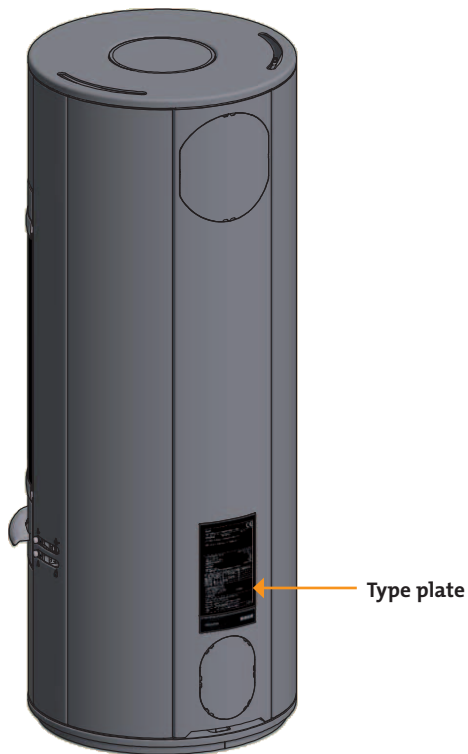

Product registration number

All Scan wood-burning stoves are provided with a product registration number.

The product registration number is located at the rear of the stove.

Please make a note of this number at the frontpage; you will always need to quote it when contacting your dealer or Scan A/S.



Scan 83 - Series		CE	
Freestanding room heater fired by solid fuel			
Standard:	EN 13240	EC no.	90583600
Minimum distance to combustibile materials:			
Side: 400 mm - Back: 100 mm - Front: 900 mm			
DIBt Zulassungsnummer:			
CO emission at 13% O ₂ :	0,07%	896 mg/Nm ³	
Dust at 13% O ₂ :		23 mg/Nm ³	
Flue gas temperature:		280°C	
Nominal heat output:		5 kW	
Efficiency:		81%	
Fuel type:		Wood	
Operation type:		Intermittent	
The appliance can be operated in a shared flue.			
Country	Classification	Certificate/Standard	Approved by
EUR	Intermittent	EN 13240	RWE Power AG
Norway	Klasse 2	300-ELAB-1904-NS	Teknologisk Institut
Austria	15a B-VG	FSPS-Wa 2197-EN-A	RWE Power AG
Schweiz	LRV 11	VKF	RWE Power AG
Germany	BStV	1 FSPS-Wa 2197-EN	RWE Power AG
Angaben für Österreich			
Wärmeleistungsbereich:		2,6 - 5,8 kW	
Brennstoffwärmeleistung:		7,2 kW	
Zulässige Brennstoffe:		Scheitholz	
Prüfbericht:		FSPS-Wa 2197-A	
Follow assembly- and instructions manual. Use only recommended fuels. Montage- und Bedienungsanleitung beachten. Verwenden Sie nur empfohlene Brennstoffe.			
1000	Scan A/S DK 5492 Vissenbjerg	06-2013	

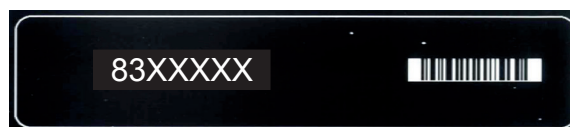

Loose parts

The flue connection piece and other loose parts are located in the stove's combustion chamber.

SCAN 83, ALL TYPES:

- 4 screws for fastening flue connection piece
- Gasket for flue connection piece
- Glove
- Repair lacquer for coloured stoves

SCAN 83-5, 83-6, 83-7 and 83-8

- 7/9 m sealing tape

Additional accessories

- Small shaped floor plate in glass or steel
- Large shaped floor plate in glass or steel
- Small corner shaped floor plate in glass or steel
- Soapstone top plate for stove with rear outlet
- Soapstone top plate for stove with top outlet
- Heat-storage stones Scan 83 Maxi, 4 items approx. 40 kg
- Rotating base
- Tile sides

Disposal of packaging

Your Scan stove may come supplied with the following packaging:

WOOD PACKAGING: The wood packaging can be reused and after final use can be incinerated as a CO₂ neutral product or sent for recycling.

FLAMINGO TOP: Send for recycling or waste disposal.

FOAM: Send for recycling or waste disposal.

PLASTIC BAGS: Send for recycling or waste disposal.

STRETCH FILM/PLASTIC FILM: Send for recycling or waste disposal.

Removal of packaging

Check that the stove is not damaged before starting to install it.

The stove comes attached to a wooden pallet on delivery. To remove the packaging, see the illustrations below.

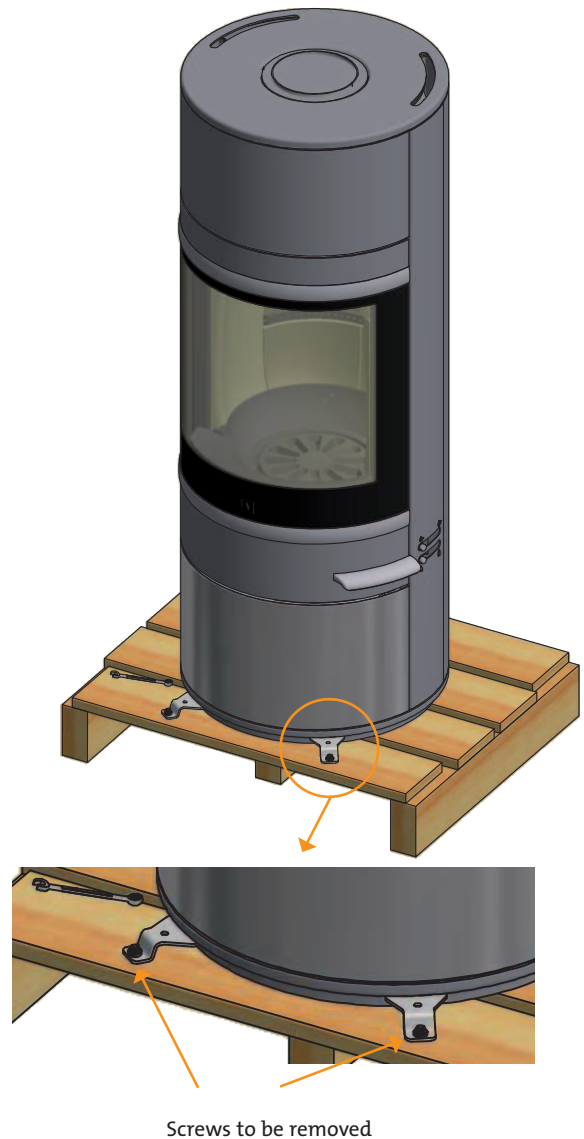

Remove the screws and fittings for securing the stove to the pallet.

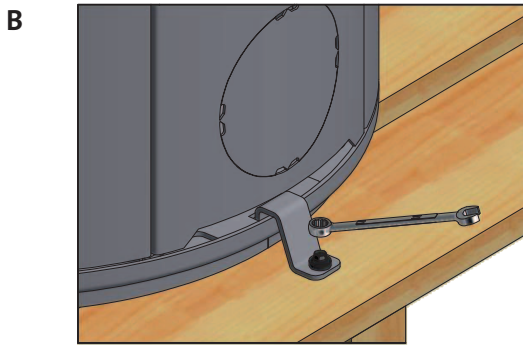
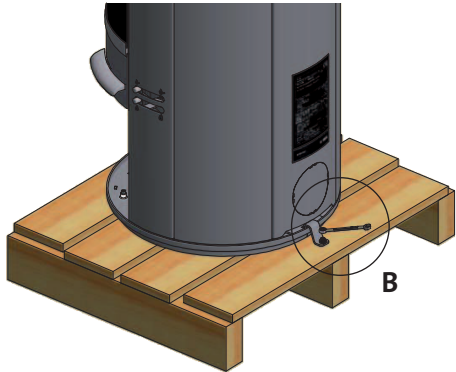

Height adjustment of stove

The stove has four adjustment screws under the stove. Use the adjustment screws to get the stove to stand straight and level.

To adjust the adjustment screws, see the illustrations below.

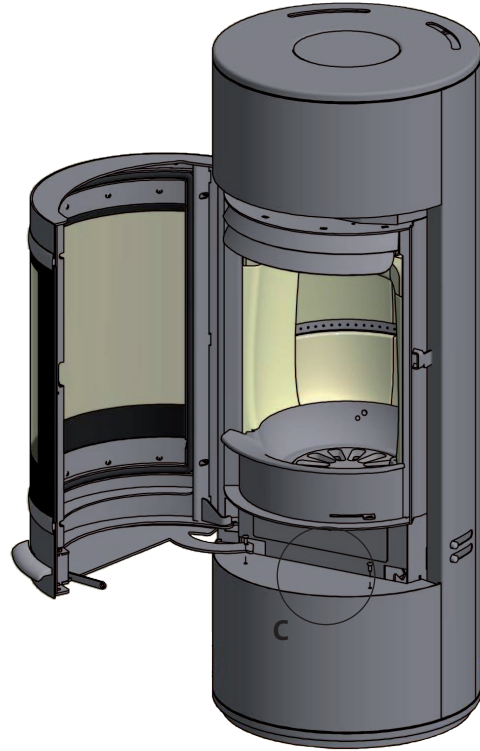

Remove the screws for the cover plate in the base.

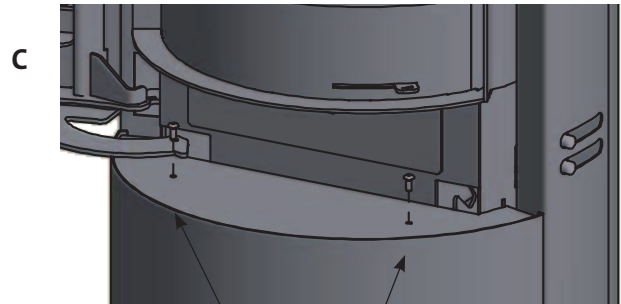

Screws to be removed

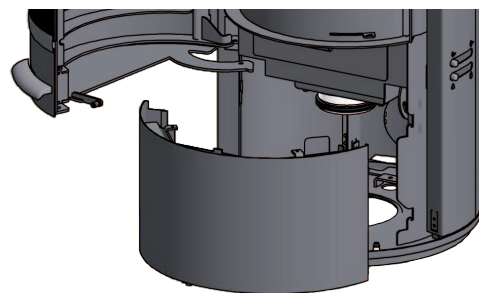

Lift off the front of the base.

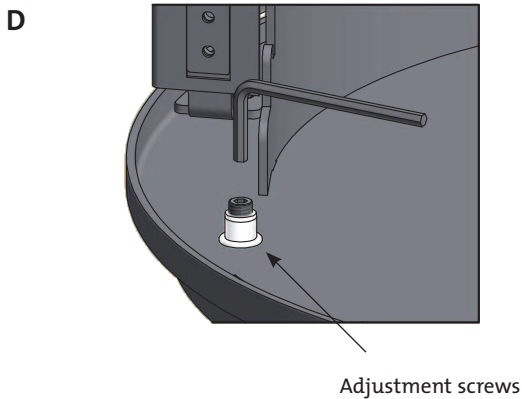

Fresh air intake

In a well-insulated house the air used for the combustion process has to be replaced. This particularly applies to houses with mechanical ventilation. There are different ways of making sure that air is exchanged. The most important thing is to ensure that there is a supply of air to the room where the wood stove is located. The external wall vent must be located as close to the wood stove as possible, and you must be able to close it when you are not using the stove.

National and local building regulations must be followed with regard to connection of a fresh air intake.

Closed combustion system

You should use the closed combustion system for the wood-burning stove if you live in a newly-built, airtight home. External combustion air is connected through a ventilation pipe via the wall or floor.

It must be possible to shut off the ventilation pipe with a valve, when the stove is not in use.

Minimum $\varnothing 100$ mm ventilation pipe, maximum length: 6 metres with a maximum of one bend.

If you want external combustion air via a wall, remove the cover plate at the rear of the stove with a pair of cutting pliers. See the procedure on page 17.

Connect external combustion air via the connection piece underneath the combustion chamber.

NOTE: if the stove has a fresh air connexion or closed combustion, the ventilation pipe must be open, when the stove is in use!

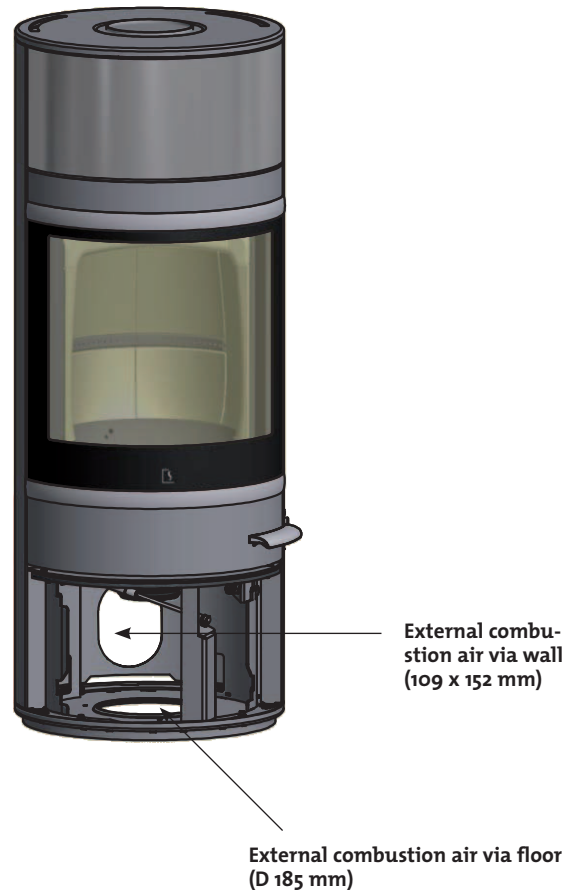

Load-bearing subsurface

All items in our product range come under the category of light-weight fireplaces and stoves and do not normally require any reinforcement of the beam structure. They can be positioned on ordinary beams/floor.

You should of course make sure that the subsurface on which the stove is positioned can indeed support the weight of the stove and, where applicable, a steel chimney, if you have opted for this solution.

Floor plate

If you are placing the stove on a flammable floor, you must comply with the national and local regulations on the size of any non-flammable subsurface required to cover the floor around the stove.

Your local Scan dealer can advise you on regulations concerning protection of flammable materials in the vicinity of your stove.

The floor plate's function is to protect the floor and flammable material against any sparks that may occur.

A floor plate can be made of steel or glass, but the stove can also be placed on clinker concrete, natural stone or similar materials.

This Scan wood-burning stove has an integrated floor plate at the bottom and can thus be placed directly on flammable material without the need for further protection underneath the stove.

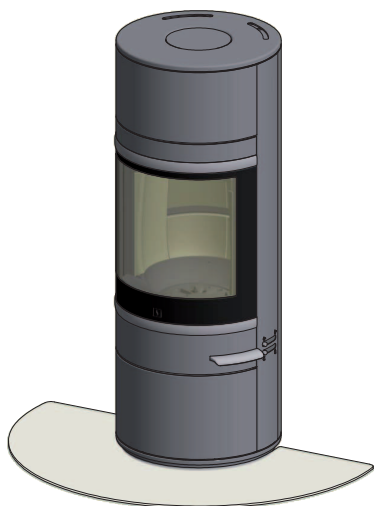

Small shaped floor plate for the Scan 83-series

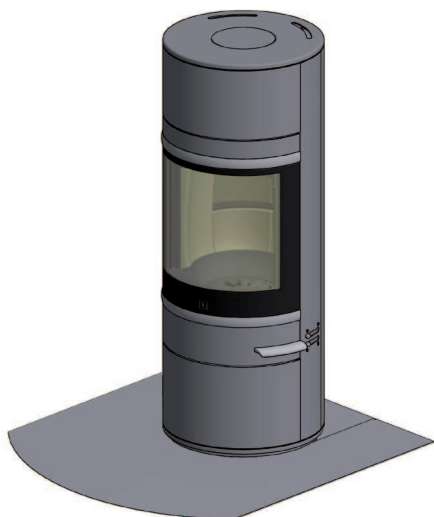

Large shaped floor plate for the Scan 83-series

Existing chimney and pre-fabricated element chimney

If you intend to connect your stove to an existing chimney, it makes sense to contact an authorised Scan dealer, or a local chimney sweep, for advice. These experts will also let you know if your chimney needs renovating.

When connecting a pre-fabricated element chimney, follow the manufacturer's connection instructions for the relevant chimney type.

Connection between stove and steel chimney

Your Scan dealer, or local chimney sweep, can advise you on choosing a make and type of steel chimney. This ensures that the chimney will match your wood-burning stove. As a general rule, the length of the chimney should not be less than 4 metres, measured from the top of the stove. Specific weather or installation conditions might require a different length.

Choosing the wrong length or diameter of steel chimney could impair functionality.

Always comply exactly with the instructions provided by the steel chimney supplier.

Requirements for chimney

The chimney must have a minimum internal diameter of 148 mm and have a T400 designation, with G for the soot fire test.

Connection with 90° elbow pipe

If you opt to connect the stove with an elbow pipe, you should use a curved elbow, as this gives a better draught.

Rotating base and 90° elbow pipe

To ensure optimum function of the rotating solution for the stove, it is important that assembly be performed in a meticulous fashion by a qualified fitter.

See the separate instructions supplied with the rotating base.

Positioning:

Positioning your wood-burning stove

The stove must be set up so that the stove itself, the flue pipe, and the chimney can all be cleaned.

Distance to furniture: 900 mm

You should however assess whether furniture or other items might become excessively dry due to being too close to the stove.

National and local regulations governing safety distances for wood-burning stoves must be complied with.

If the stove is to be connected to a steel chimney, the chimney requirements in terms of safety distances must be met.

Distance to flammable materials

These distances apply for an uninsulated flue pipe/insulated flue pipe, all the way down to the stove, having a minimum of 30 mm insulation.

Installation along a rear wall.

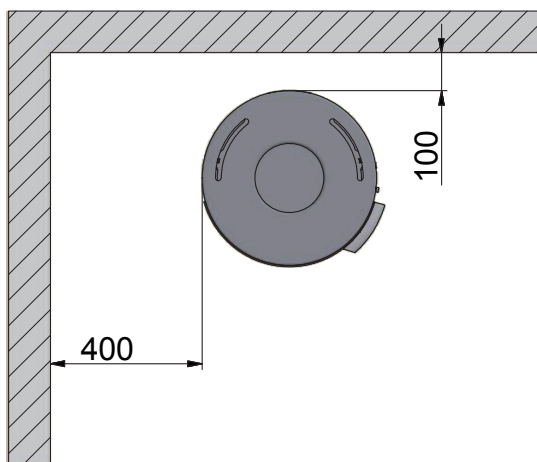

45° Corner installation

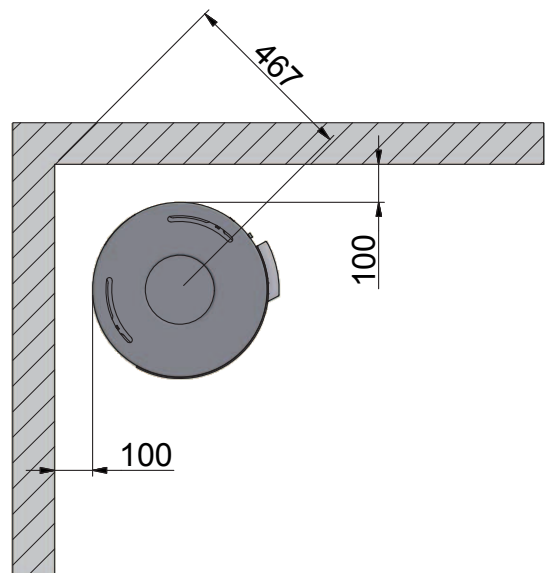

Installation with rotating base

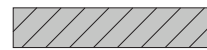
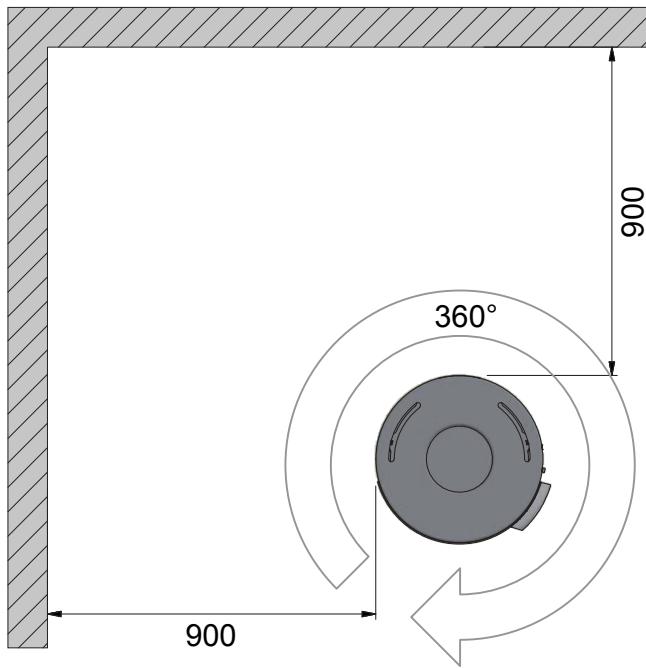

Flammable materials

Fitting the flue connection piece in the top outlet

The stove is prepared for a top outlet from the factory.

Lift the steel top plate off the stove.



Place the gasket on the flue connection piece

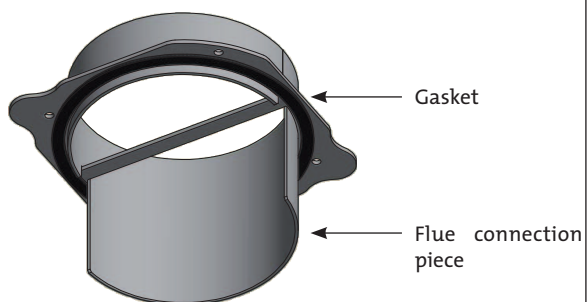

Tighten the flue connection piece with the screws provided and reposition the steel top.



E

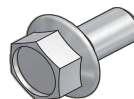

4 x M5x10 mm screws

Fitting the flue connection piece in the rear outlet

The stove is prepared for a top outlet from the factory.

The gasket for the flue connection piece, flue connection piece and screws can be found in the stove's combustion chamber.

Lift the steel top plate off the stove.



Unscrew the stove's heat shield and remove it.

Using cutting pliers, cut off the cover plate from the rear plate and the heat shield (only Scan 83 Maxi) at its securing points.

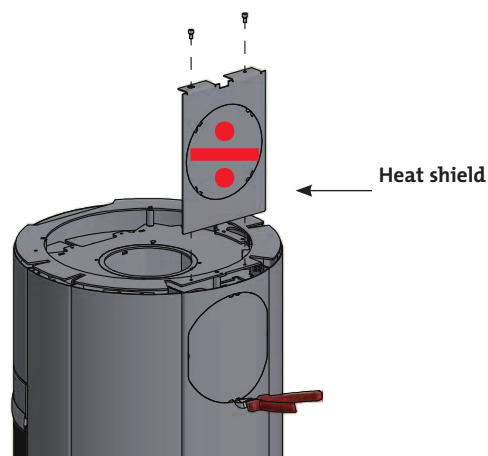

Maxi

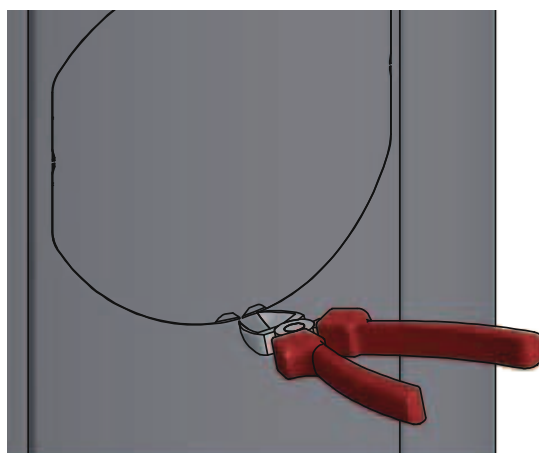
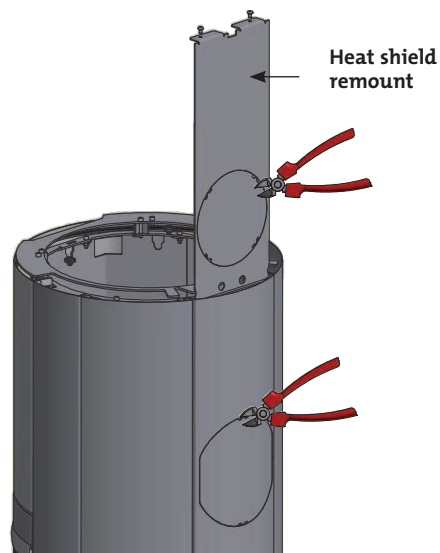



Remove the cover from the stove's rear outlet.

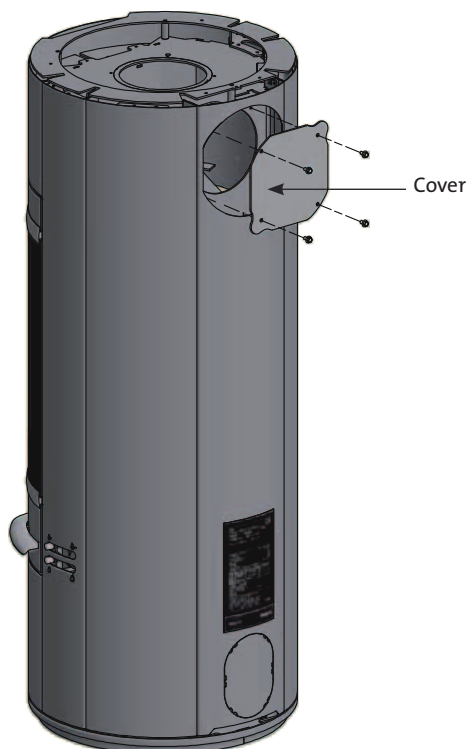

Place the gasket on the flue connection piece

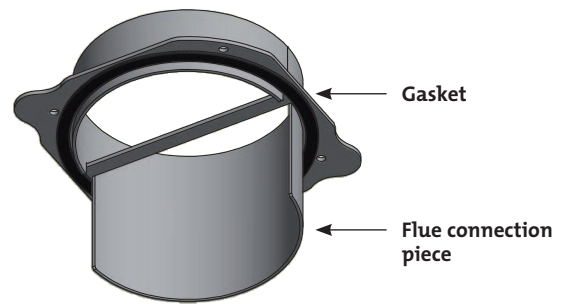

Tighten the flue connection piece with the screws provided.

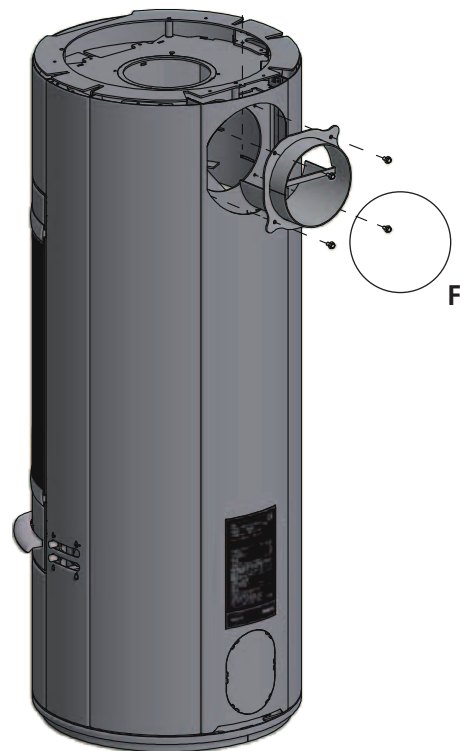

F

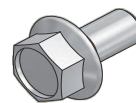

4 x M5x10 mm screws

Fit the cover in the stove's top outlet and tighten it.
Reposition the steel top.



H

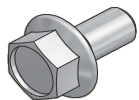

4 x M5x10 mm screws



I

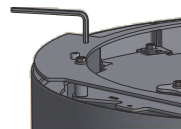

Fitting the natural stone sides

The natural stones should be mounted in the described order.

Important! Start the mounting with stone No. 1.

Natural stones are made from a natural material and may therefore vary in structure and form.

After mounting, clean the natural stones with water.

Scan 83-5, 83-6, 83-7 and 83-8 come supplied with loose natural stones

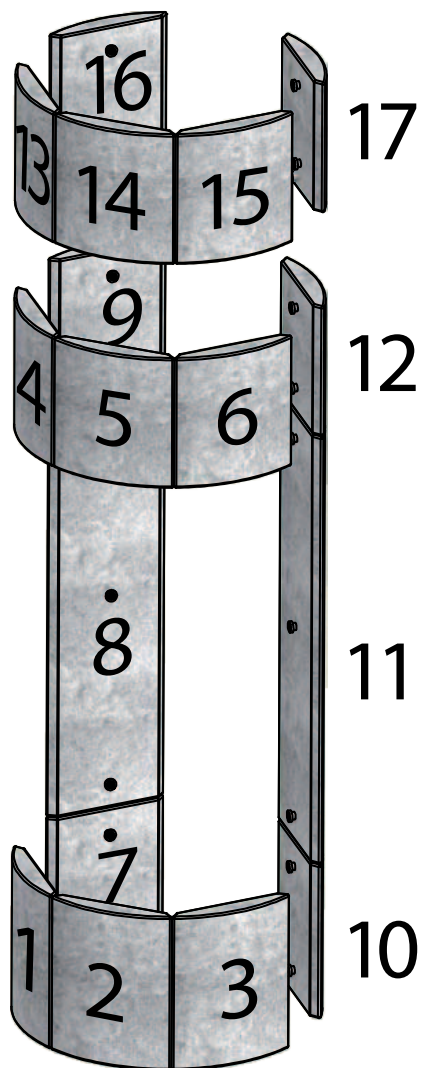

Remove the steel top plate and the cover plate in the stove's base

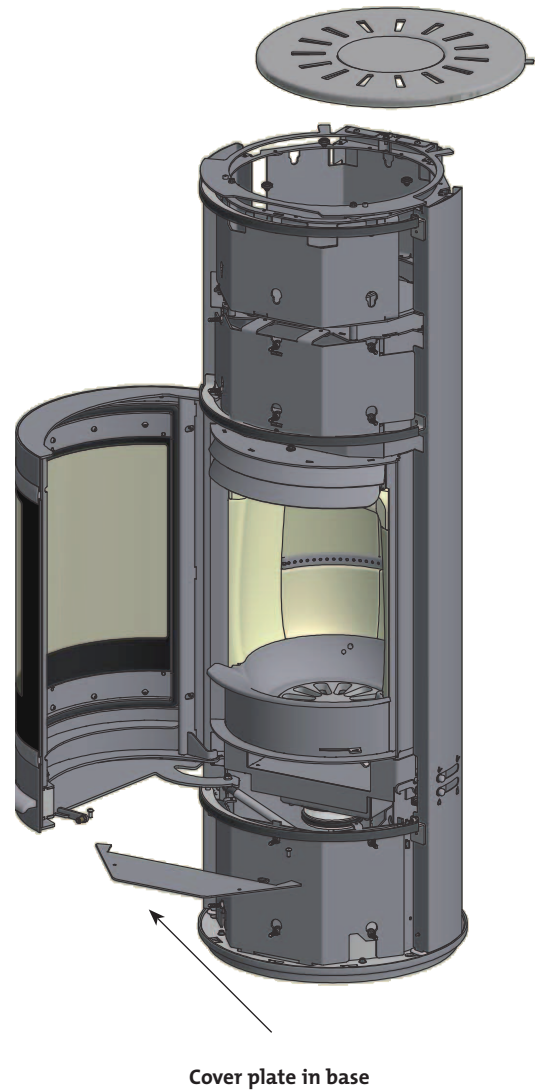

Shorten the sealing tape supplied (7 metres/9 metres) to suitable lengths and attach to the sides of the stove as indicated below.

Scan 83-5 / Scan 83-6

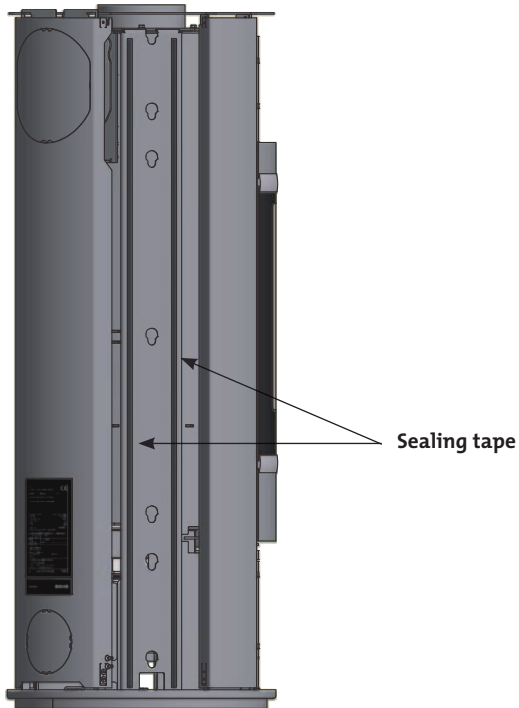
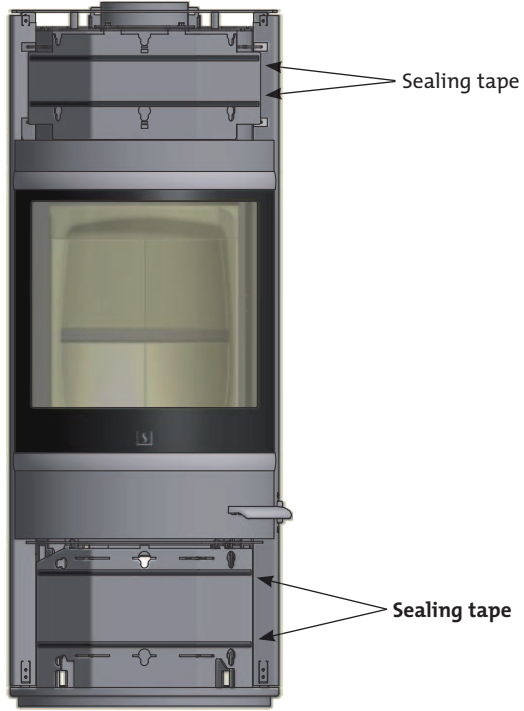

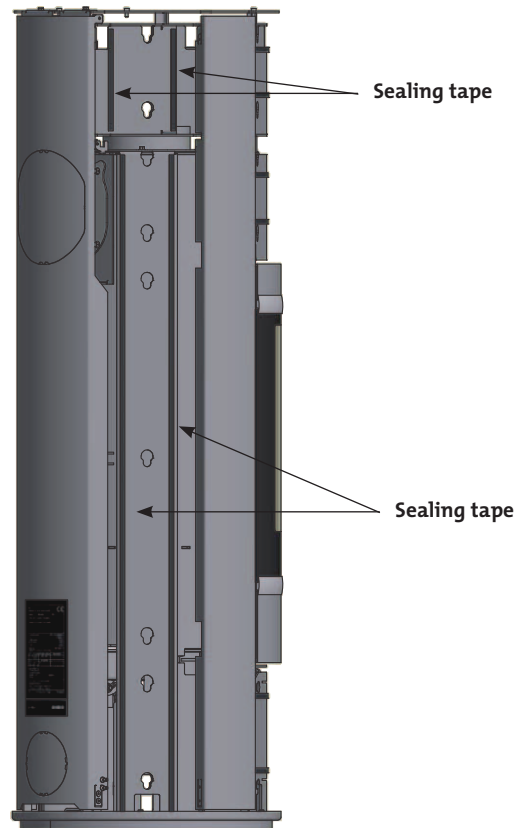
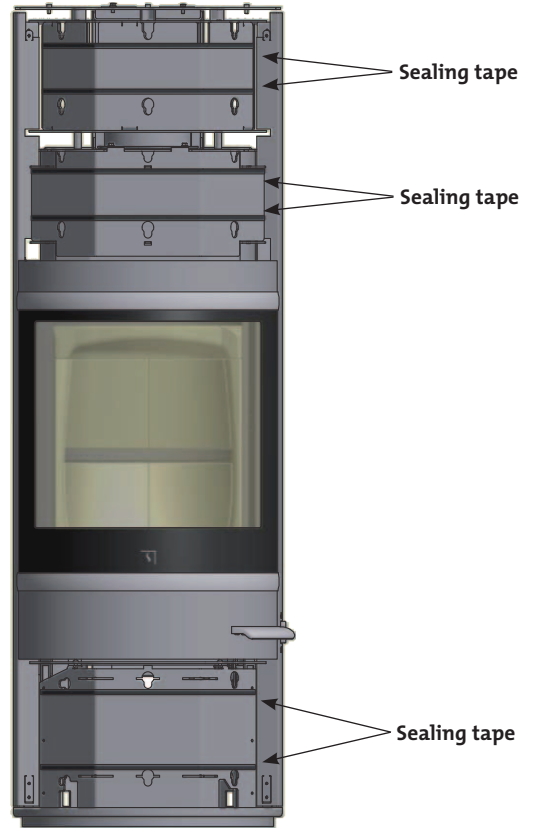

Scan 83-7 / Scan 83-8

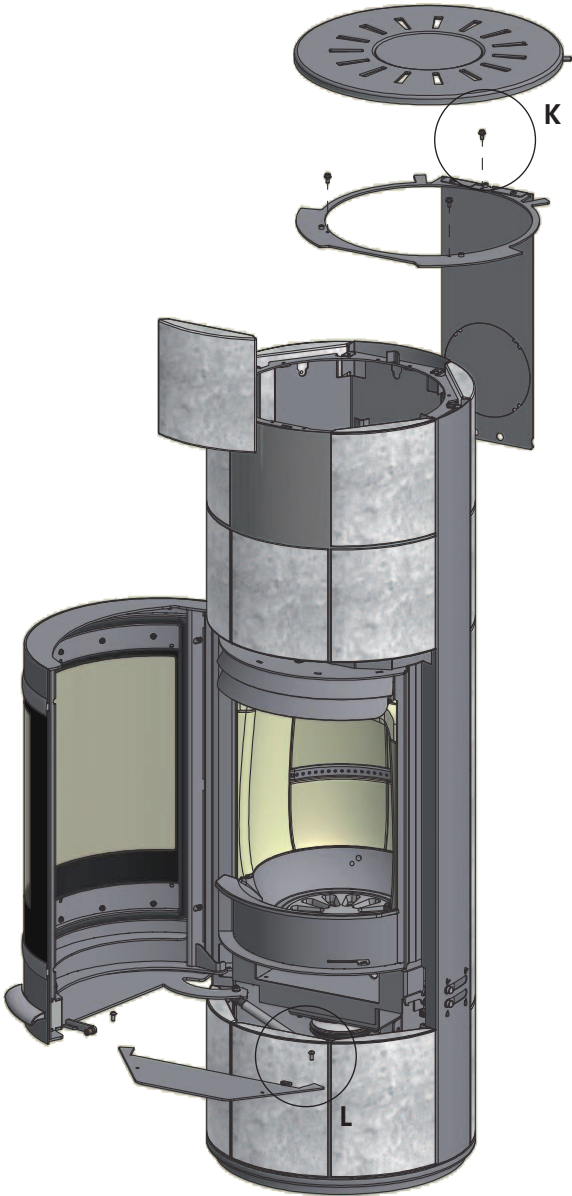

Fit the natural stones and fit the cover plate to the base.
Reposition the steel top.

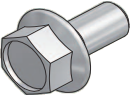

K  3 x M5x10 mm screws

L  2 x M5x12 RH socket head cap screws



Fitting the natural stone top

You can buy a natural stone top as an accessory. Place the natural stone top on top of the steel top plate.

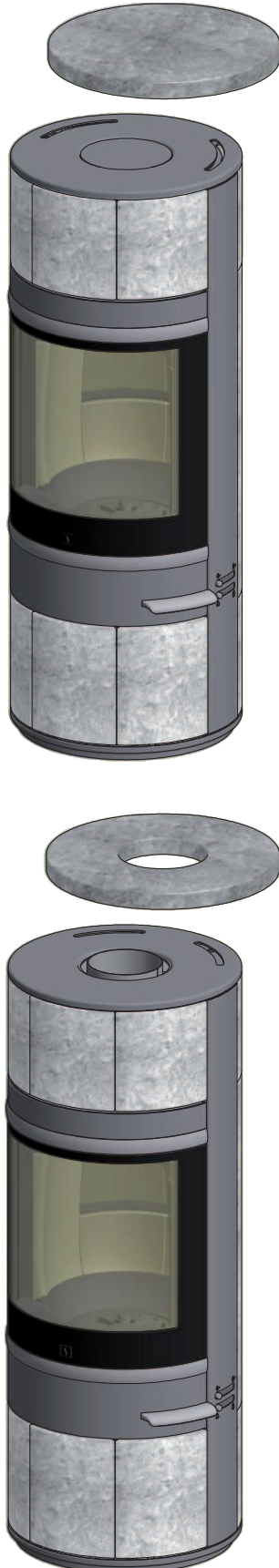

Heat-storage stones

Heat-storage stones are made from a special material with a high heat capacity. The stones are heated when the stove is on and keep releasing heat, after the fire has gone out. This extends the time over which the stove remains warm.

Heat-storage stones are placed in the top of the stove, as illustrated below.

Scan 83 Maxi models:
Scan 83-3, 83-4, 83-7, and 83-8



Mounting of the ceramic tiles

Please note that the tiles are made of natural materials, and therefore they can vary in structure and form. There may be minor cracks in the glazing which is especially visible in the bright colours.

Scan 83-5/ 83-6

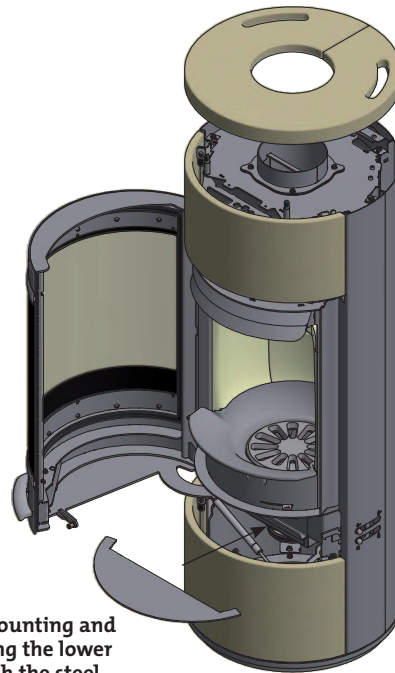
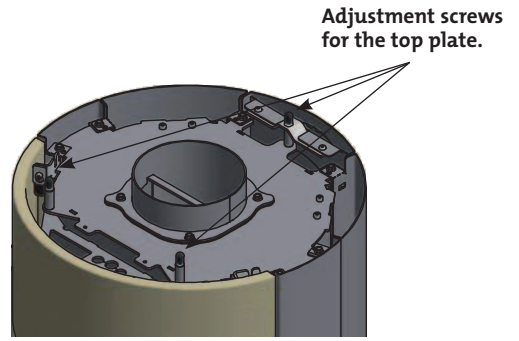
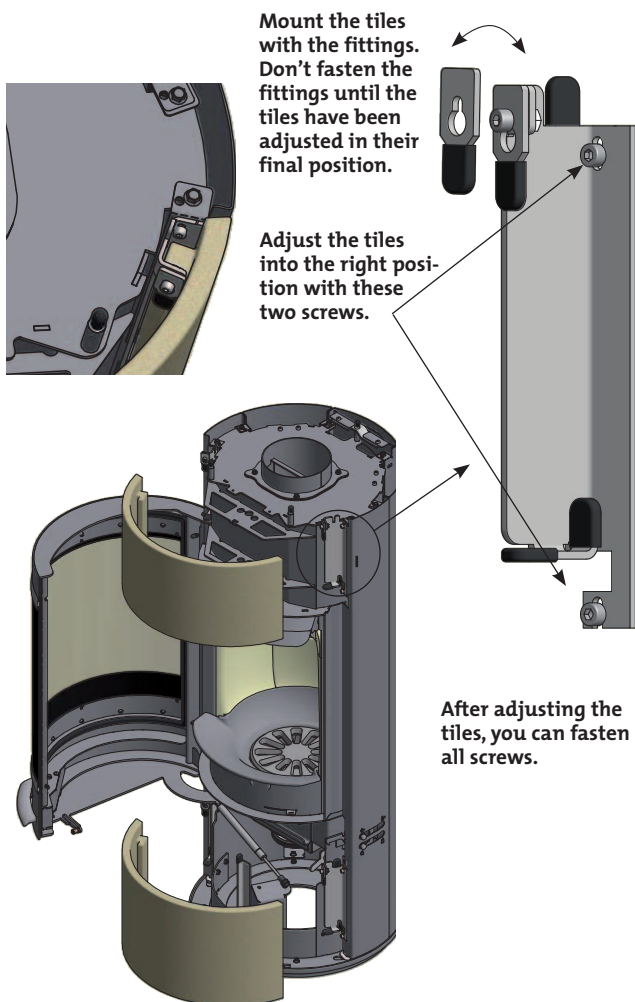
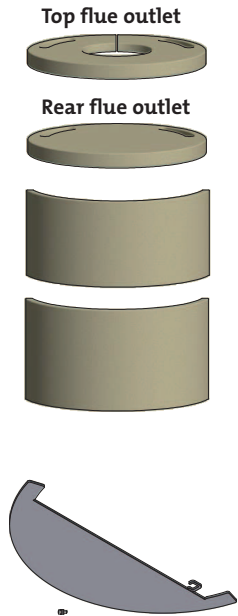

Cleaning of the ceramic tiles

The tiles must be cold before being cleaned. Use only a special soap that you can buy at your dealer.

CB technology (Clean Burning)

The stove is equipped with CB technology. In order to ensure optimal combustion of gases released during the combustion process, air passes through a specially developed system of channels. The heated air is conducted into the combustion chamber through the holes in the rear lining of the combustion chamber and at the baffle plates. This airflow is controlled by the rate of combustion and therefore cannot be regulated. Wood must not be added above the CB rail.

Primary air

The primary air regulation mechanism is used for lighting the fire, or to accelerate combustion when you add more wood. During continuous operation, the primary air vent can be 30% to 80% open if you use hard wood fuel, such as oak and beech. You can close the primary air vent if you use soft wood, such as birch or pine, for fuel.

Setting for normal load: 30-50%

Secondary air

Secondary air is pre-heated and fed indirectly to the fire. At the same time, the secondary airflow cleans the glass pane to prevent build-up of soot. If you over-restrict the secondary airflow, soot can build up on the glass pane. The secondary airflow determines the heat output from your wood stove.

Setting for normal load: 60-90%

Baffle plates

The baffle plates are located in the upper part of the combustion chamber. The plates hold back smoke, making sure it stays inside the combustion chamber for a longer time before escaping through the chimney. This reduces the flue gas temperature as the gases have more time to dissipate heat to the stove. The baffle plates must be removed for sweeping; see "Maintaining your wood-burning stove". Note that the baffle plates are made of porous, ceramic material, and are liable to break easily. You should therefore handle them with care. The baffle plates are subject to wear and tear and not covered by the warranty.

Ash container

Open the door of the stove to access the ash container under the combustion chamber.

The ash container must always be closed during operation.

The ash container must not become too full and must therefore be emptied at regular intervals.

Handle for riddling grate

The stove is equipped with a riddling grate that empties ash from the combustion chamber down into the ash container when activated.

The riddling grate must remain half open during operation.

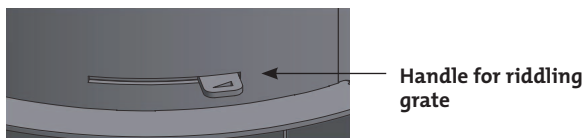
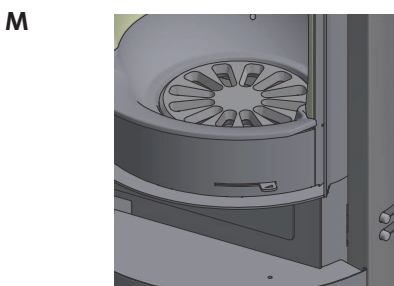
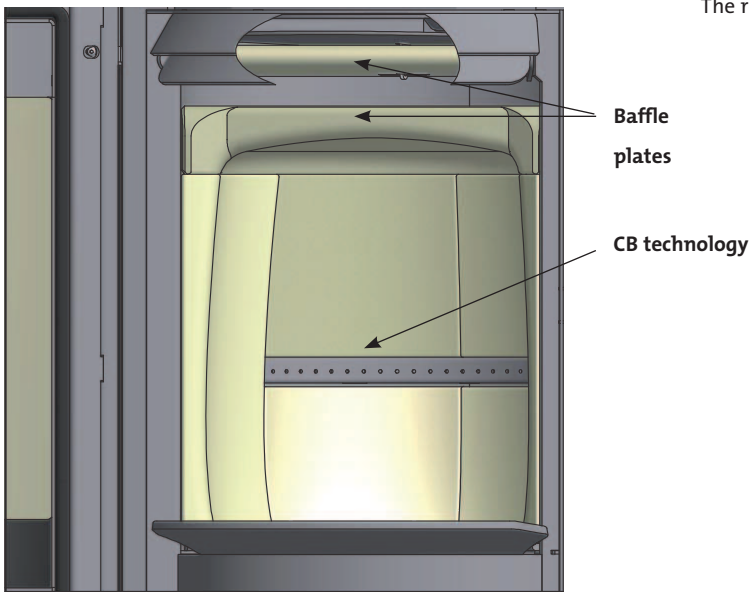

↔
Riddling grate
Closed - Open

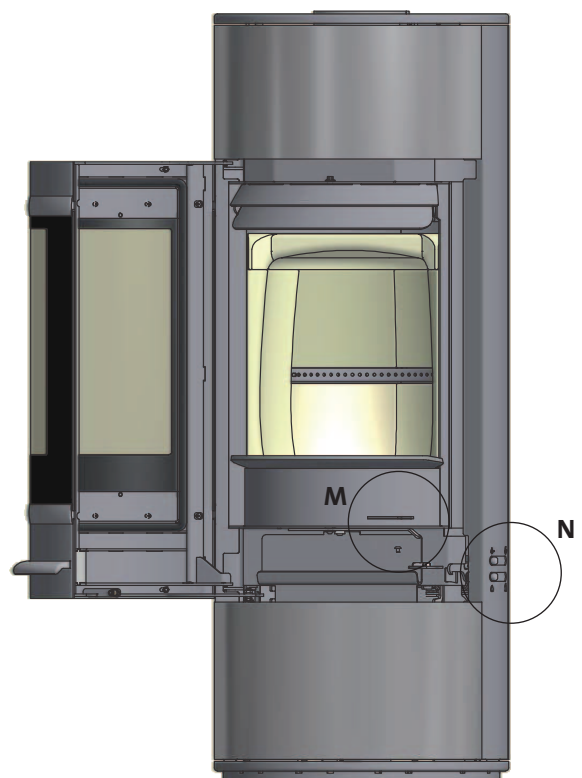

Adjustment of air supply, primary and secondary damper

N

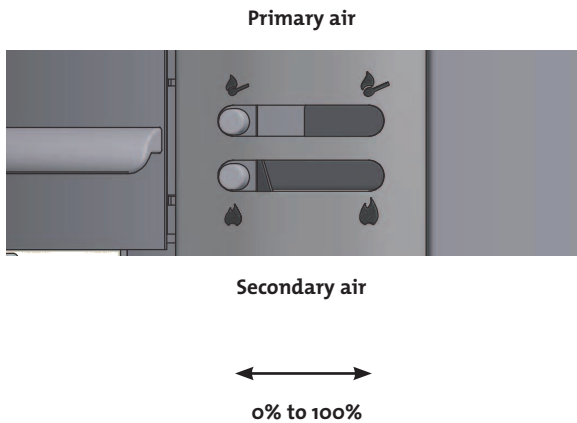

Ash container

Ash container in closed position

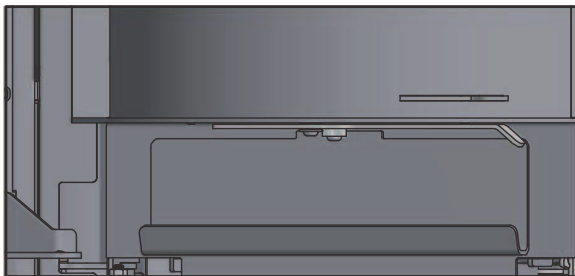

Ash container in open position



The Clean Air Act 1993 and Smoke Control Areas

Under the Clean Air Act local authorities may declare the whole or part of the district of the authority to be a smoke control area. It is an offence to emit smoke from a chimney of a building, from a furnace or from any fixed boiler if located in a designated smoke control area. It is also an offence to acquire an "unauthorised fuel" for use within a smoke control area unless it is used in an "exempt" appliance ("exempted" from the controls which generally apply in the smoke control area).

The Secretary of State for Environment, Food and Rural Affairs has powers under the Act to authorise smokeless fuels or exempt appliances for use in smoke control areas in England. In Scotland and Wales this power rests with Ministers in the devolved administrations for those countries. Separate legislation, the Clean Air (Northern Ireland) Order 1981, applies in Northern Ireland. Therefore it is a requirement that fuels burnt or obtained for use in smoke control areas have been "authorised" in Regulations and that appliances used to burn solid fuel in those areas (other than "authorised" fuels) have been exempted by an Order made and signed by the Secretary of State or Minister in the devolved administrations.

Further information on the requirements of the Clean Air Act can be found here : <http://smokecontrol.defra.gov.uk/>

Your local authority is responsible for implementing the Clean Air Act 1993 including designation and supervision of smoke control areas and you can contact them for details of Clean Air Act requirements"

The secondary air valve has been modified, so that it does not close completely but has an opening corresponding to the position used at the lowest emission test.

You can use any type of wood as fuel.

This stove has been recommended as suitable for use in smoke control areas when burning wood.

Refueling on to a low fire bed

If there is insufficient burning material in the firebed to light a new fuel charge, excessive smoke emission can occur. Refuelling must be carried out onto a sufficient quantity of glowing embers and ash that the new fuel charge will ignite in a reasonable period. If there are too few embers in the fire bed, add suitable kindling to prevent excessive smoke

Fuel overloading

The maximum amount of fuel specified in this manual should not be exceeded, overloading can cause excess smoke.

Operation with door left open

Operation with the door open can cause excess smoke. The appliance must not be operated with the appliance door left open except as directed in the instructions.

Dampers left open

Operation with the air controls or appliance dampers open can cause excess smoke. The appliance must not be operated with air controls, appliance dampers or door left open except as directed in the instructions.

Environmentally-friendly operation

Avoid turning down your wood-burning stove to the point where no flames are visible from the wood, as this leads to poor combustion and low efficiency. The gases released from the wood will not be burnt off due to the low temperature in the combustion chamber. Some of the gases will condense in the stove and flue system as soot, and this could lead to your chimney catching fire at a later point. The residual smoke which exits the chimney will pollute the surrounding area and cause an unpleasant smell.

Lighting

We recommend the use of fire lighters, or similar products, which are available from your Scan dealer. Using fire lighters helps light the wood more quickly and keeps the combustion process clean.

Never use liquid lighting fuels!

Due to the large size of this stove's combustion chamber, it is important that the wood used to light the fire is dry so as to generate enough heat to ensure clean combustion.

The combustion chamber lining will turn black when the fire is lit. It will burn clear again the next time wood is added.

“Top down” lighting

4 pieces of wood approx. 20-25 cm long with a weight of approx. 0.4-0.5 kg per piece (illustrations 1 and 2).

15-20 thin pieces of firewood of about 20 cm in length, with a total weight of approx. 0.8 kg (illustrations 3 to 5).

4 fire lighters in bag or block form

Place the pieces of wood, firewood and fire lighters in the combustion chamber as shown in illustrations 1 to 6.

Set the primary and secondary airflow controls to maximum for the entire lighting phase.

Top down lighting is a more environmentally-friendly way of lighting the fire and helps to keep the glass area as clean as possible.



Position fire lighters between the pieces of firewood.



Continuous operation

It is important to obtain as high a temperature as possible in the combustion chamber. This results in best possible use of the stove and fuel, as well as achieving clean combustion. In this way you will avoid build-up of soot on the combustion chamber lining and glass pane. During operation, you should not see any smoke; just a movement in the air that indicates combustion is in progress.

After completing the lighting phase, you should have a good layer of embers in the stove; you can then start operation of it proper. Add two pieces of wood at a time: they should be about 0.4 to 0.5 kg in weight and about 20-25 cm long.

NB: The wood must catch fire quickly; this is why we recommend setting the primary airflow fully open. Operating the stove at too low a temperature and with too little primary air can lead to gases igniting, which can damage the stove.

When adding wood, always open the glass door carefully to prevent smoke escaping. Never add wood while the fire is burning nicely.

Operating the stove in the spring or autumn

In the spring/autumn transition period, where there is less need for heating, we recommend you light the stove "top down" once, perhaps adding just two pieces of wood as above to ensure that the combustion chamber lining burns clean again.

The function of the chimney

The chimney is the wood-burning stove's motor; its performance determines how well your stove will work. The draught in the chimney creates negative pressure in the wood-burning stove. The negative pressure draws the smoke out of the stove and takes in air through the combustion air damper to fuel the combustion process. Combustion air is also used for the airwash system that keeps the window clear of soot.

The draught in the chimney is created by the difference in temperature inside and outside the chimney. The higher the difference in temperature, the better the draught. This is why it is important that the chimney reaches operating temperature before you reduce the damper settings to restrict combustion in the stove (a brickwork chimney will take longer to reach operating temperature than a steel chimney). It is very important that the operating temperature is reached as quickly as possible on days when the draught in the chimney is poor due to unfavourable wind and weather conditions. You need to get a few flames going as quickly as possible. Chop the wood extra thin; use an extra fire lighter etc.

After longer periods without use, you must check the chimney flue for blockages.

You can connect several units to the same chimney. You should however first check the relevant regulations in this respect.

No matter how good your chimney is, it will not perform well if you do not use it correctly. Equally, a poor chimney may well give you acceptable results if you use it correctly.

Using your stove in various weather conditions

The way the wind affects the chimney can have a big impact on how your stove reacts under various wind loads; you may need to adjust the airflow to achieve good combustion. Fitting a damper in the flue pipe may also help, as it will allow you to regulate the draught under changing wind loads.

Fog and mist can also have a big impact on chimney draught; you may need to use other settings for the combustion air to achieve good combustion.

General notes

Please note! Parts of the wood-burning stove, especially the outer surfaces, become hot during use. Due care should be exercised.

Never empty ashes into a flammable container. Ashes can contain glowing embers long after you finish operating the stove. When the stove is not in use you can close the dampers to avoid a draught through the stove.

If the stove has not been used for some time, you should check the flue passageways for potential blockages before relighting.

Chimney fire

In the event of a chimney fire, keep the stove door, the ash container, and all dampers on the stove closed. In an emergency, call the fire brigade.

We recommend that you get a chimney sweep to check the chimney before using the stove again.

Handling fuel

Selecting wood/fuel

You can use any type of wood as fuel. However harder woods, such as beech or ash, are generally better for heating, as they burn more evenly and create less ash. Other woods, such as maple, birch and spruce, are excellent alternatives.

Preparation

The best fuel is obtained where the tree has been felled and the wood sawn and split before May 1st. Remember to cut the wood to match the size of the combustion chamber. We recommend a diameter of 6-10 cm. The length should be about 6 cm shorter than that of the combustion chamber to leave enough space for air to circulate. If the diameter of the wood is greater than the above, it should be split down its length. Wood that has been split dries faster.

Storing

You need to store the sawn and split wood in a dry place for 1-2 years before it will be dry enough to burn. Wood dries faster if you stack it in an airy place. Before using it, it is a good idea to store the wood for a few days at room temperature. Remember that wood absorbs moisture from the air during autumn and winter.

Moisture

To avoid problematic impact on the environment and to ensure optimum operating economy, the wood should be perfectly dry before it can be used as fuel. Maximum wood moisture content should not exceed 20%. A moisture content of 15-18% will deliver best efficiency. An easy way of checking wood moisture content is to knock the ends of the two pieces of wood together. If the wood is moist, the sound will be slightly muffled.

If you use wood that is too damp, most of the heat it produces will be used up in evaporating the water. The stove will accordingly not increase in temperature, nor emit heat to the room as a result. This is obviously poor economy, and it will cause soot build-up on the glass pane, in the stove and in the chimney. Operation using moist wood also pollutes the environment.

Understanding the terms used to designate quantities of wood

Various terms are used to designate quantities of wood. Before you buy wood, it makes sense to familiarize yourself with these terms. There are various brochures, in public libraries for example, that cover this topic.

Use of the following as fuel is illegal

Painted, pressure impregnated, or glued wood, or sea driftwood. Nor should you ever burn chipboard, plastics, or treated paper. These contain substances which are hazardous to human health, to the environment, your stove, and your chimney. In short – make sure you only use proper wood.

Wood types	Kg Dry wood/m ³	Compared to beech
Hornbeam	640	110%
Beech/Oak	580	100%
Ash	570	98%
Maple	540	93%
Birch	510	88%
Pine	480	83%
Fir	390	67%
Poplar	380	65%

Maintaining your wood-burning stove

Apart from having the chimney swept, your wood-burning stove does not require any regular maintenance. However, we do recommend servicing at least once every two years.

Only use original spare parts for maintenance and repair of your stove.

NB: Make sure the stove is cold before starting maintenance or repair work.

Painted surfaces

Clean your wood-burning stove by wiping it down with a dry, lint-free cloth.

If the paint finish gets damaged, you can purchase repair paint in spray form from your Scan dealer. As slight differences in colour shade are possible, we recommend you spray a larger area to achieve a natural blend. For best results, apply repair spray when the stove is warm enough for you to just keep your hand on it, but no hotter.

Cleaning the glass

Our wood-burning stoves are designed to prevent serious soot build-up on the glass. The best way to achieve this is to make sure you have a good supply of combustion air. It is also very important that the wood is dry and the chimney correctly dimensioned.

Even if you operate the stove in accordance with our instructions, a slight film of soot may still accumulate on the glass. You can easily remove this film by wiping the glass down with a dry cloth and then with a cloth dampened with glass cleaner. Please note that the glass cleaner is not to get into contact with the gaskets, as this can discolour the glass permanently.

The detergent must not come into contact with the painted surfaces as these can be damaged.

Combustion chamber lining

Slight cracks can appear in the combustion chamber lining due to moisture or sudden heating/cooling. These cracks have no influence on the output or lifetime of your stove. However, if the lining starts to crumble and fall out, you must replace it. The combustion chamber lining is not covered by the warranty.

Seals

All wood-burning stoves have seals made of ceramic material fitted to the stove, the door and/or the glass. These seals are subject to wear and tear and must be replaced when necessary.

Seals are not covered by the warranty.

Sweeping the chimney and cleaning your stove

Follow national and local regulations for sweeping the chimney. We recommend having the stove cleaned regularly by a chimney sweep.

Before cleaning the stove and sweeping the flue pipe and chimney, we recommend removing the baffle plates.

Removing the baffle plates

See section "Servicing".

Checking the stove

Scan A/S recommends that you check your stove thoroughly after sweeping/cleaning. Check all visible surfaces for cracks. Check that all joints are tight and that the gaskets are correctly seated. Worn or deformed gaskets should be replaced.

Servicing

We recommend that the stove be thoroughly serviced at least once every two years. The service should include the following:

- Lubricate hinges using copper grease.
- Check gaskets. Replace any that are broken or have gone soft.
- Check the combustion chamber bottom and riddling grate.
- Check heat-insulating materials.

The stove must be serviced by a qualified fitter. Only use original spare parts.

Disposal of stove parts

Steel/cast iron: Send for recycling.

Glass: Dispose of as ceramic waste.

Combustion chamber lining: Vermiculite or chamotte is not recyclable. Dispose of as waste.

Baffle plates: Vermiculite or chamotte is not recyclable. Dispose of as waste.

Gaskets/sealing rope: Dispose of as waste.

Removing the baffle plates

Be very careful when removing the baffle plates from the stove.



Combustion chamber lining

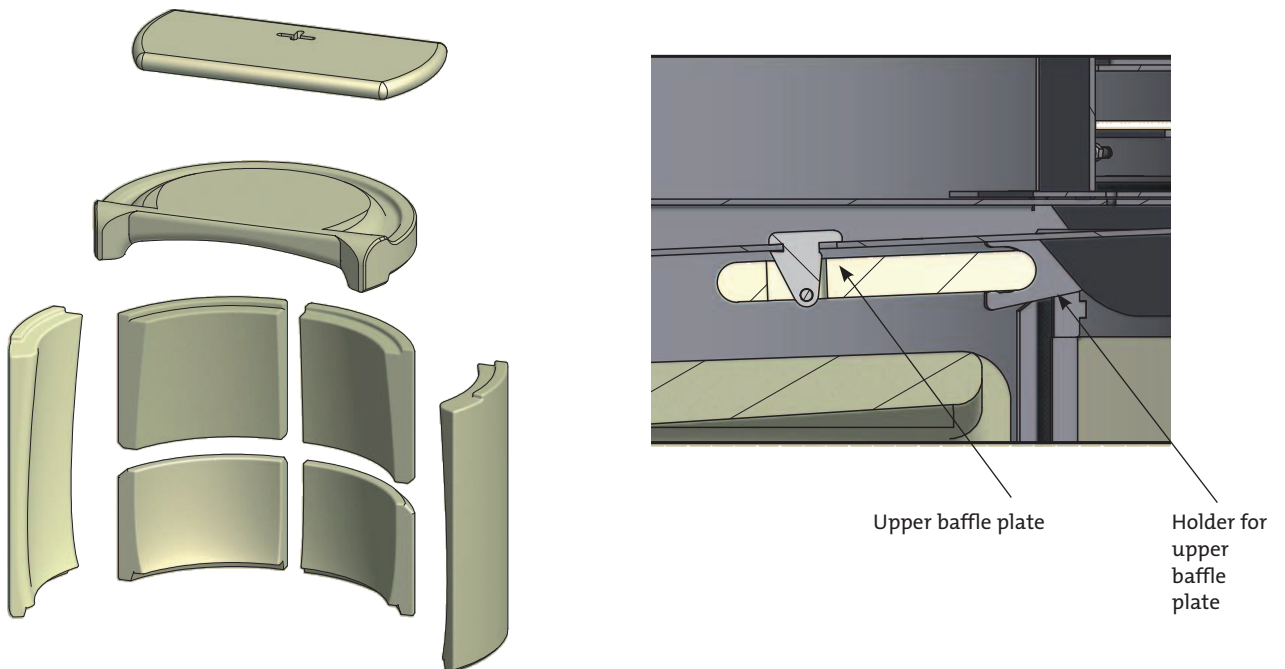

Lift the lower baffle plate.

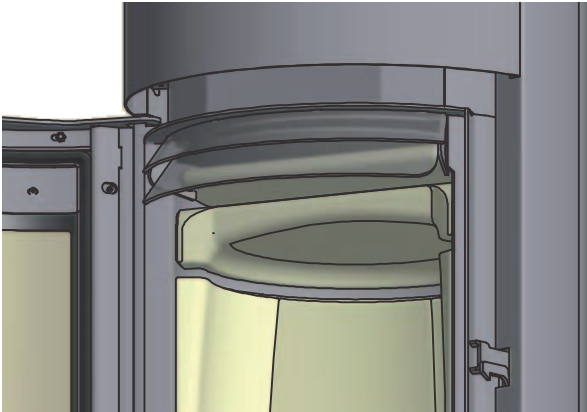

Turn the baffle plate 90°, and lower it out through the combustion chamber.

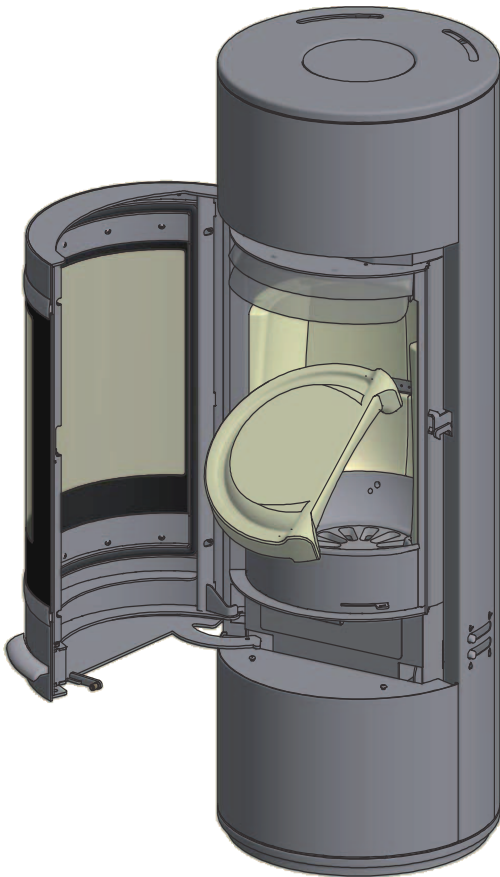

Lift the upper baffle plate and remove the pin. Pass the baffle plate edge-first and downwards out through the combustion chamber.

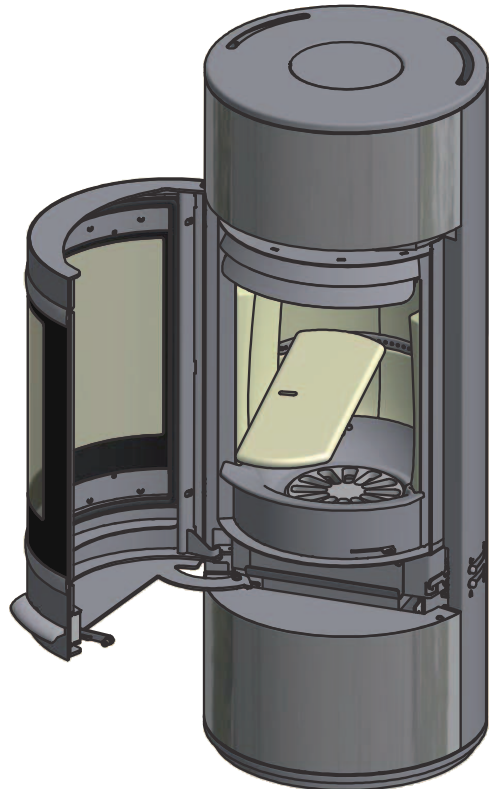
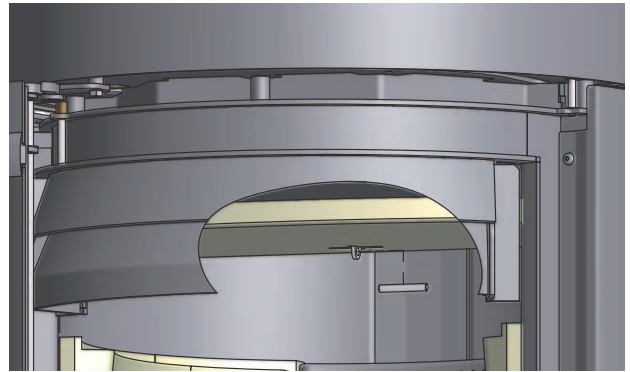
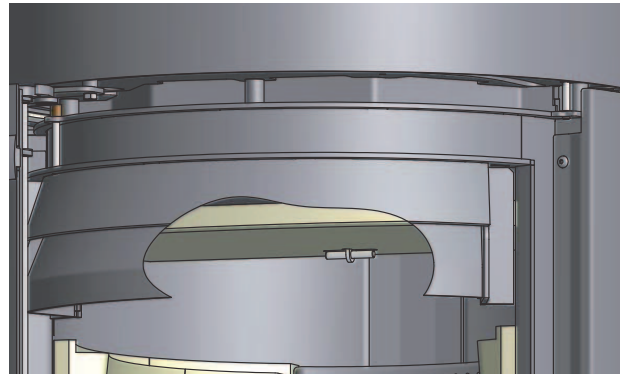

The baffle plate holder may fall out when the baffle plate is taken out of the stove. See the illustrations below for how to fit it.

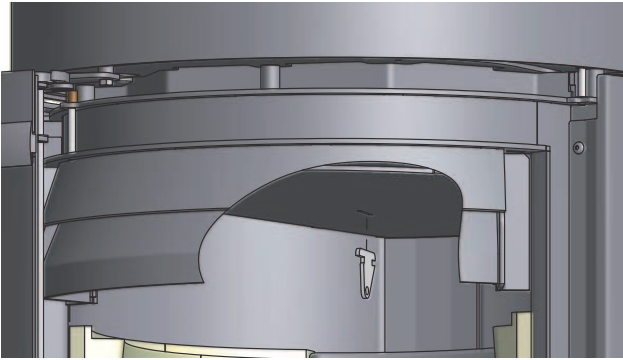

Removing the combustion chamber lining

Carefully lift the sides and rear plates of the combustion chamber lining out of the stove.

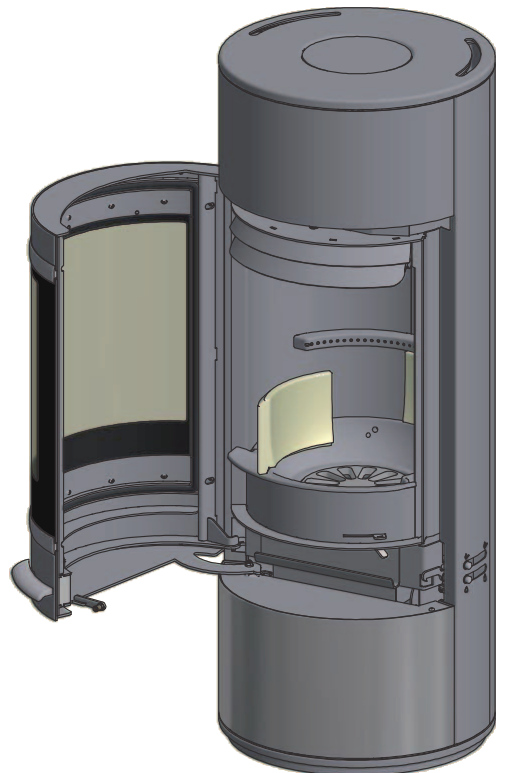
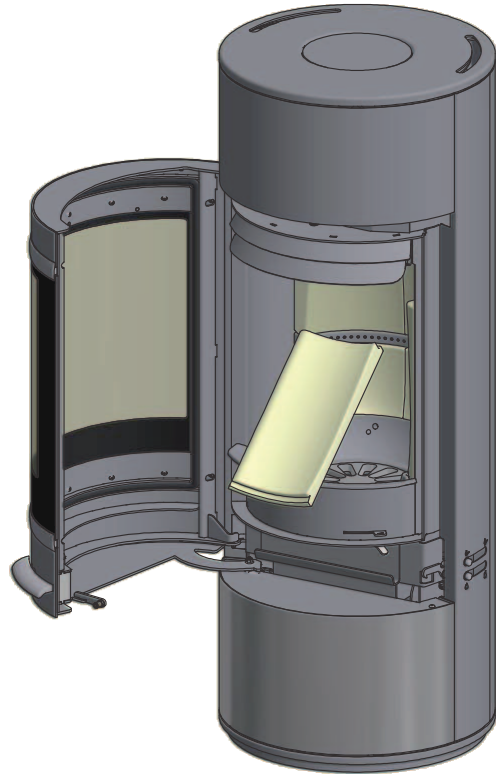

Troubleshooting

Smoke escaping

- Damp wood
- Chimney not drawing properly
- Chimney is not properly dimensioned for the stove
- Check if the smoke gas pipe/chimney are blocked
- Is the chimney the right height for its surroundings?
- At rear outlet, check that the flue pipe does not obstruct the chimney draught
- Vacuum in room
- The door is opened before the embers have burned down sufficiently

Wood burning too quickly

- The air valves are set incorrectly
- The baffle plates are incorrectly mounted or missing
- Inferior firewood (waste wood, pallets etc.)
- Chimney too large

Soot build-up on glass

- Incorrect secondary airflow setting
- Excessive primary air
- Damp wood
- Wood pieces too large on lighting
- Inferior firewood (waste wood, pallets etc.)
- Chimney not drawing sufficiently
- Vacuum in room

Excessive soot build-up in chimney

- Poor burning (more air required)
- Damp wood

The surface of the stove is turning grey

- Overheating (see instructions for heating)

Poor heating performance of stove

- Damp wood
- Not enough wood
- Inferior wood quality with low fuel value
- Baffle plates are not fitted correctly

Smell and sound of the stove

- The lacquer on the stove hardens when you use the stove for the first time; this can cause an odour. Open a window or a door for ventilation, and make sure the stove is heated up sufficiently to avoid odours later.
- When heating up and cooling down, the stove may make some clicking noises. These are due to the huge temperature differences to which the material is exposed and do not indicate any product defects.

The door does not close

It may occur during transport that the locking device moves out of its correct position, so that the door does not close properly. This can easily be adjusted, see below.

1. Remove the cover plate

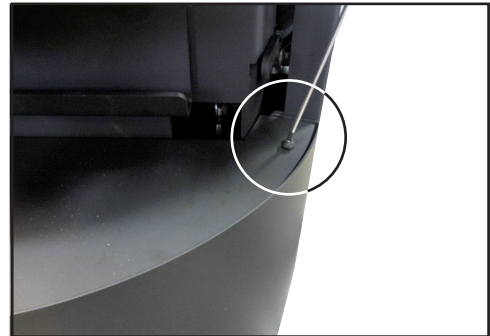

2. Locking device

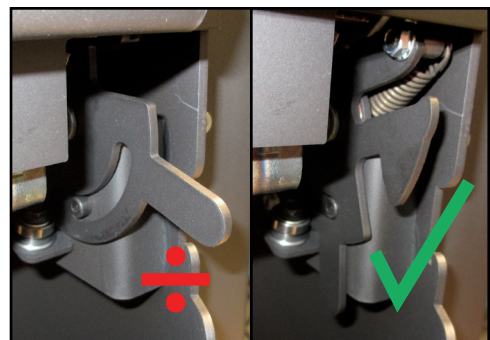

3. Press the locking device in its correct position



4. Mount the cover plate



Warranty

All wood-fired Scan products are made of high-quality materials and subject to strict quality controls before leaving the factory. We give a warranty of 5 years on manufacturing errors or defects.

You must quote your stove's product registration number when you contact us or your authorised Scan dealer with a warranty claim.

The warranty covers all parts which in the opinion of Scan A/S require repair or replacement due to manufacturing or construction error

The warranty applies to the original purchaser of the product only, and is not transferable (except on prior sale).

The warranty covers only damage caused by manufacturing or construction errors.

The following parts are not covered by the warranty

- Wear and tear parts, such as the combustion chamber liners, baffle plates, riddling grate, glass, and seals (except for defects which were present on delivery).
- Defects caused by external chemical and physical influences during transportation, storage and assembly, or at a later time.
- Soot build-up caused by poor chimney draught, damp wood, or improper use.
- Costs of additional heating in connection with a repair.
- Transport costs.
- Costs for setting up, removing the wood stove.

This warranty is void

- In case of incorrect installation (the installer is responsible for observing and complying with legal requirements and local bylaws, along with this Assembly- and Instructionsmanual for the wood-burning stove and accessories).
- In case of improper use, and/or use of prohibited fuels, non-original spares (see this Assembly- and instructions manual).
- If the product registration number of the stove has been removed or damaged.
- In case of repairs that do not comply with our instructions or instructions by an authorised Scan dealer.
- In case of any manipulation of the original state of this Scan product or its accessories.
- This warranty is only valid in the country to which this Scan product was originally supplied.

Always use original replacement parts, or parts recommended by the manufacturer.

